



X **City Greening**

Bid Documents Greening Project 2024-Fall 24-08, 24-09 & 24-10

On Behalf of the City of Mansfield Ohio
Mansfield Permitting and Development Office
3rd floor, 30 N. Diamond St.
Mansfield, Ohio 44902
419-775-9688
mmilliron@ci.mansfield.oh.us

Bid Date:
December 6, 2024

9:00 am

NOTICE TO CONTRACTORS

Sealed proposals for the “**Greening Project 2024-Fall 24-08, 24-09 & 24-10**” will be received by the City of Mansfield at the City of Mansfield Permitting and Development Office – 3rd floor, 30 N. Diamond St. - Mansfield, OH 44902 until **9:00 AM, December 6, 2024**. The Bids will be opened and publically read aloud at **9:01 AM, December 6, 2024** in the City of Mansfield Permitting and Development Office – 3rd floor at above address.

Scope of Work and Bid Documents may be secured from City of Mansfield www.ci.mansfield.oh.us or Richland County Land Bank www.richlandcountylandbank.org

This Project must be accompanied by either a bid bond in an amount of 10% of the bid or by certified check, cashier’s check upon a solvent bank in the amount of not less than 10% of the bid amount in favor of the aforesaid City of Mansfield.

Bids shall be **SEALED AND MARKED** as Bid for: **Greening Bid Documents Project 2024-Fall 24-08, 24-09 & 24-10** and mailed or delivered to:

City of Mansfield Permitting and Development Office – 3rd floor,
30 N. Diamond St.
Mansfield, OH 44902

City of Mansfield awards bids to the Lowest and Best bidder. “Best” includes, but is not limited to: Contractor’s financial position, including property, city, state and/or federal tax status, judgment liens, known experience, prior dealings with City and/or Land Bank, available equipment, ability to execute work in accordance with all applicable guidelines and relevant laws, and performance on previous contracts. Bid will be considered if bid complies with bid specifications in all material respects and contains no irregularities or deviations from the specifications which would affect the amount of the bid or otherwise give the bidder a competitive edge. We reserve the right to waive any informality or to reject any bid(s) or all bids.

City of Mansfield will award bids to the lowest and best bid contingent upon City of Mansfield Board of Control approval. Contractor is required to sign and deliver the contract on or before the 14th day following the date on and of the Notice of Award from the Richland County Land Bank and/or the City of Mansfield. In the event Contractor fails to deliver its signed contract by such 14th day, then the Notice of Award shall expire and be withdrawn and cancelled. The City of Mansfield MAY offer the contract to the next lowest bidder. Contractor understands that City of Mansfield will not accept bids from any contractor who has any incomplete Greening(s) past Contract Termination Date from previously signed contracts. The Greening of property CANNOT begin until 10-day EPA notices have been filed and completed, also all applicable terms and conditions listed herein have been met. City of Mansfield reserves the right to limit number of contracts awarded to one (1) to first time bidders for the purpose of permitting the Board to determine new bidder’s ability to perform, execute and timely complete each contract in order to prevent the loss of funding

After opening all bids, each one must be evaluated using the criteria established in the Invitation for Bid (IFB). Federal regulations require that the award be made to the lowest and best bidder whose bid conforms to the bid document. Normal policy and legal guidelines provide that bids shall be awarded to the lowest and best bidder who submits a responsive bid.

INSTRUCTIONS TO BIDDERS

1. **RECEIPT AND OPENING OF BIDS:** The Contracting Agency, City of Mansfield (herein called the "City of Mansfield"), invites bids on the form attached hereto, all blanks of which must be appropriately filled in. Bids will be received by the City of Mansfield until **9:00 am, December 6, 2024** at said office and be publicly opened and read aloud. The envelopes containing the ***bids must be sealed***, addressed to City of Mansfield Permitting and Development Office, and designated as bid for: **Greening Bid Documents Project 2024-Fall 24-08, 24-09 & 24-10**

City of Mansfield may consider unacceptable any bid not prepared and submitted in accordance with the provisions hereof and reserves the right to waive any informalities or reject any bid(s) and all bids. Any bid may be withdrawn prior to the above scheduled time for the opening of bids or authorized postponement thereof. Any bid received after the time and date specified shall not be considered. ***Contractor understands that City of Mansfield may not accept bids from any contractor who has any incomplete demolition(s) past Contract Termination Date from previously signed contracts.***

City of Mansfield may award the Demolition Contract for the Project to the lowest and best bidder on the Project.

2. **CONTRACTOR FORMS:** Each contractor is required to submit to City of Mansfield for City of Mansfield to keep on file a W-9, Contractor Verification Form, Non-Collusion Affidavit, the Conflict of Interest Form, the Drug-Free Workplace Notification, Certification of Bidder Regarding Equal Employment Opportunity, Proof of Workers Compensation and a copy of required insurance papers. All of the above-mentioned forms must be dated within the year the work is being completed. If the required forms are not on file, Contractor must submit forms with bid package.
3. **PREPARATION OF BID:** All blank spaces for bid prices must be filled in, in ink or typewritten, in both words and figures, and the foregoing Certifications must be fully completed and executed when submitted. In case of discrepancies of written words and figures, the prices written in words shall govern.
4. **METHOD OF BIDDING:** City of Mansfield invites a lump sum bid on the Project as indicated in the Bid Form. Bidder must bid on the entire Project in order for the bid to be considered for the Project. **One contract will be executed for the Project by the successful bidder, after acceptance by City of Mansfield. PAYMENT FOR CONTRACT WILL BE MADE AFTER ALL WORK LISTED IN BID SPECIFICATIONS HAS BEEN COMPLETED AND APPROVED.** Therefore, the Project need have one bid security and one performance bond encompassing the entire Project.
5. **QUALIFICATIONS OF BIDDER:** City of Mansfield make such investigations as it deems necessary to determine the ability of the bidder to perform the work, and the bidder shall furnish to City of Mansfield all such information and data for this purpose as City of Mansfield may request. City of Mansfield reserves the right to reject any bid if the evidence submitted by, or investigation of, such bidder fails to satisfy City of Mansfield that such bidder is properly qualified to carry out the obligations of the contract and to complete the work contemplated therein. Conditional bids will not be accepted. **All bidders (Contractors and Sub-contractors) must be registered as per each local municipal code as determined by location of Greening project.**
6. **AWARD OF BID:** City of Mansfield will award bids to the lowest and best bid contingent upon City of Mansfield Board of Control approval. Contractor is required to sign and deliver the contract on or before the 14th day following the date on and of the Notice of Award from the Richland County Land Bank and/or the City of Mansfield. In the event Contractor fails to deliver its signed contract by such 14th day, then the Notice of Award shall expire and be withdrawn and cancelled. The City of Mansfield MAY

offer the contract to the next lowest bidder. Contractor understands that City of Mansfield will not accept bids from any contractor who has any incomplete Greening(s) past Contract Termination Date from previously signed contracts. The Greening of property CANNOT begin until all applicable terms and conditions listed herein have been met.

7. **CONDITIONS OF WORK:** Each bidder must inform himself/herself fully of the conditions relating to the Project and the employment of labor thereon. Failure to do so will not relieve a successful bidder of his/her obligation to furnish all material and labor necessary to carry out the provisions of his/her contract. Insofar as possible, the contractor in carrying out the work must employ such methods or means as will not cause any interruption of or interference with the work of any other contractor.
8. **OBLIGATION OF BIDDER:** At the time of the opening of bids, each bidder will be presumed to have inspected the sites and to have read and to be thoroughly familiar with the Scope of Work and contract documents (including all addenda(s)). The failure or omission of any bidder to examine any form, instrument or document shall in no way relieve any bidder from any obligation in respect of his/her bid.
9. **EXAMINATION OF SITE:** Each bidder shall, and is hereby directed to, inspect any site of the proposed work and judge for himself/herself as to all the circumstances affecting the cost and progress of the work and shall assume all patent and latent risks in connection herewith.
10. **SOIL CONDITIONS: GREENING:** It is the desire of City of Mansfield that we leave our Greening sites in a condition that improves the visual appearance and value of the property and surrounding neighborhoods. Site must be free from debris, tires, rocks and other foreign materials. Site grade must match existing grade unless otherwise instructed.
11. **WORKING FACILITIES:** The bidders must fully apprise themselves of the conditions and difficulties that may be encountered in the execution of the Work at this site.
12. **ADDENDA AND INTERPRETATIONS:** No official interpretation of specifications or other pre-bid documents will be made to any bidder orally.

Every request for such interpretation should be in writing addressed to the City of Mansfield Permitting and Development Office – 3rd floor, 30 N. Diamond St. - Mansfield, OH 44902 to be given consideration. Any and all such interpretations and any supplemental instructions will be in the form of written addenda to the specifications which, if issued, will be distributed by e-mail only, not later than three (3) days prior to the date fixed for the opening of bids. Failure of any bidder to receive any such addendum or interpretation shall not relieve such bidder from any obligation under his/her bid as submitted. All addenda(s) so issued shall become part of the contract documents.

13. **INSPECTIONS:** Contractor is responsible to obtain all required signatures on Greening Inspection Sheet and submit said sheet with final invoice.
14. **SIGNATURE OF BIDDERS:** The firm, corporate or individual name of the bidder must be signed in ink in the space provided for the signatures on the proposed blanks. In case of a corporation, the title of the officer signing must be stated and such officer must be thereunto duly authorized and the seal of said corporation duly affixed. In the case of a partnership, the signature of at least one of the partners must follow the firm name, using the term "member of the firm". In case of a Limited Liability Company ("LLC"), the signature of at least one of the members must follow the company name, using the term "authorized member of company". In the case of an individual, use the terms "doing business as", or "sole owner". The bidder shall further state, in his proposal, the name and address of each person or corporation interested therein.
15. **NOTICE OF SPECIAL CONDITIONS:** Attention of the bidder is particularly called to those parts of the General Contract Conditions and other contract documents and specifications which deal with the

following:

- a. Insurance requirements
- b. Requirement that all subcontractors be approved by the municipality where the Greening will be taking place
- c. Time-for-completion and liquidated damages requirements
- d. Safety standards
- e. **The Contractor must be registered with municipality or township as required by local ordinance where the Greening is to take place or with the county where none exist.**

16. **OBLIGATIONS UPON COMPLETION OF CONTRACT: PAYMENT FOR CONTRACT WILL BE MADE AFTER ALL WORK LISTED IN BID SPECIFICATIONS HAS BEEN COMPLETED AND APPROVED.** Upon completion of the Contract, but prior to payment, the contractor shall submit all of the following documents:

- a. Complete invoice including all approved change order cost
- b. Completed Contractors Final Release of Liens and Warranty form

17. **FOREIGN CORPORATIONS AND CONTRACTORS**

A. **Foreign Corporations**

Definition: "Foreign Corporation" means a corporation incorporated under the laws of another state. No contract shall be entered into with a foreign corporation until the Secretary of State has certified that such corporation is authorized to do business in Ohio; and until, if the bidder so awarded the Contract, is a person nonresident of this State, such person has filed with the Secretary of State Power of Attorney designating the Secretary of State as its agent for the purpose of accepting service of summons in any action brought to enforce the bond(s) of this Project under Sections 4123.01 to 4123.94, inclusive of the Revised Code.

BID FOR INDIVIDUAL RESIDENTIAL GREENING PROJECT 2024-Fall 24-08, 24-09 & 24-10

Date _____

Proposal of _____ (hereinafter called "Bidder") * a corporation or a limited liability company, organized and existing under the laws of the State of Ohio, a partnership, or an individual doing business as _____.

To the City of Mansfield (hereinafter called "City of Mansfield").

The Bidder, in compliance with your invitation for bids for the Greening work as indicated in the *Bid Documents*, including without limitation, the Greening Contract, for the proposed Work and being familiar with all of the conditions surrounding the Greening Project including the availability of the Project, of the materials and labor, hereby proposes to furnish all labor, materials, and supplies, and to perform the Work in accordance with the Bid and Contract Documents, within the time set forth herein, and at the prices stated. These prices are to cover all expenses incurred in performing the Work required under the Contract Documents, of which this proposal is a part.

Bidder hereby agrees to commence work under the Contract on or before a date to be specified in the written "**Notice to Proceed**" of the City of Mansfield. The Contractor shall complete the Work within **Thirty (30) days** thereafter Notice being given that the demolition phase has completed and is therefore ready for Greening Phase per the scope of work, unless Contractor has requested IN WRITING AN EXTENSION of the Contract beyond the Termination Date for good cause and the Contractor and City of Mansfield have consented in writing to such extension, which consent shall not be unreasonably withheld. Any extension of the Contract shall be made to a specified date (the "Extension Date"). Extension of time request must be received prior to Termination Date. It is agreed that time is of the essence under the Contract. There shall be deducted from the Contract Price, as an applicable credit to City of Mansfield, Fifty and No/100 Dollars (\$50.00) per incomplete Greening* for each consecutive calendar day that the completion of the Greening for specific property extends beyond the Termination Date or the Extension Date, as applicable. **PAYMENT FOR CONTRACT WILL BE MADE AFTER ALL WORK LISTED IN BID SPECIFICATIONS HAS BEEN COMPLETED AND APPROVED.** The Contractor shall not be liable, however, for excusable delays, which include, but are not limited to:

- a. Acts of a government restricting labor, equipment or materials by reason of a declared emergency;
- b. Causes beyond the control and without the fault or negligence of the Contractor, including, but not limited to, acts of God, fires, floods, epidemics, quarantine restrictions, strikes, lockouts, freight embargoes, weather conditions of unusual severity, unavoidable delay in transportation, and unusual casualties; or
- c. Weather conditions of unusual severity including but not limited to the following (Any extension of time requested for any of the following conditions must be accompanied with proof from National Weather Service).
 - 1. Winter Storm Warnings for Richland County issued by National Weather Service
 - 2. Wind Chill Warning for Richland County issued by National Weather Service
 - 3. Flood warnings for area where property is located issued by National Weather Service
 - 4. High Wind Warning for Richland County issued by National Weather Service
 - 5. Tornado Warning for Richland County issued by National Weather Service
 - 6. Excessive Heat Warning for Richland County issued by National Weather Service; or
- d. Changes ordered in the Work pursuant to any Change Order(s).

***Completed Greening means all work listed in bid specifications including but not limited to replacing sidewalks and curbs.**

Greening Project 2024-Fall 24-08, 24-09 & 24-10

Scope of Work

A. Option 1: Four inches of top soil, final grade of site, seed and straw for entire site; *The site (defined as entire parcel(s) plus any disturbed portion of any adjoining property) must be covered with topsoil free of any debris, trash, stone, brick, porcelain, or loose organic material. In preparation for seeding of the site, the entire lot and any adjoining lots disturbed by the demolition must be loosened to a depth of 1-1/2 to 2" creating a seed bed that is raked smooth and free of any debris, tree roots, ruts, clods, stone, tire/excavator tracks, and voids. The final grade must match the existing grade of any undisturbed portion of the lot and adjoining lots. A starter fertilizer applied prior to seeding. SEED TYPE: 70% TURF TYPE TALL FESCUE, 20% ELITE PERENNIAL RYEGRASS, 10% ANNUAL RYEGRASS applied 8-10 pounds per 1,000 square feet. Contractor must also add 8-10 pounds 10-20-10 fertilizer per 1,000 square feet. Straw is to be applied at 3-4 bales/1000 sq. ft. Any slopes greater than 5/1 will need to be covered with biodegradable erosion control netting secured by biodegradable pins/staples. We are looking for a smooth lush green carpet of grass on the entire parcel.*

or

Option 2: Four inches of top soil plus HydroSeeding for entire site; *The site (defined as entire parcel(s) plus any disturbed portion of any adjoining property) must be covered with topsoil free of any debris, trash, stone, brick, porcelain, or loose organic material. In preparation for seeding of the site, the entire lot and any adjoining lots disturbed by the demolition must be loosened to a depth of 1-1/2 to 2" creating a seed bed that is raked smooth and free of any debris, tree roots, ruts, clods, stone, tire/excavator tracks, and voids. The final grade must match the existing grade of any undisturbed portion of the lot and adjoining lots. HydroSeeding where seed and any combination of fertilizer, lime, boistimulants, moisture retention polymers, tackifiers and other additives are combined with water and a hydroseeding mulch to form a slurry that is sprayed onto the ground to establish vegetation and control erosion. SEED TYPE: 70% TURF TYPE TALL FESCUE, 20% ELITE PERENNIAL RYEGRASS, 10% ANNUAL RYEGRASS applied 8-10 pounds per 1,000 square feet. Contractor must also add 8-10 pounds 10-20-10 fertilizer per 1,000 square feet along with 46 pounds of mulch per 1000 square feet. We are looking for a smooth lush green carpet of grass on the entire parcel.*

B. If indicated, sidewalk replacement in accordance with applicable zoning requirements

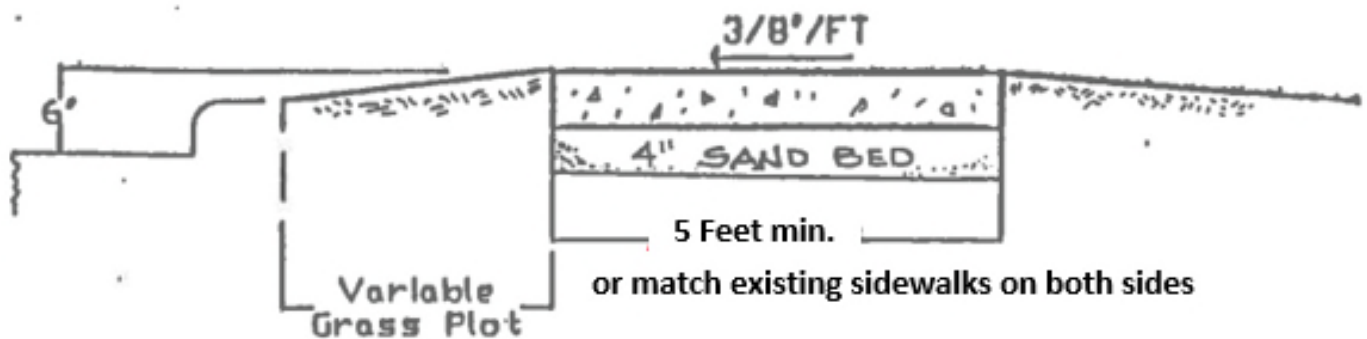

Concrete sidewalks to be four inches thick and saw cut every four (4) feet minimum.

C. If indicated, curb replacement in accordance with applicable zoning requirements

If indicated, curb replacement in accordance with applicable zoning requirements. The contractor shall cut the roadway along the face of the curb at a minimum depth of 15" to ensure a clean separation between the

roadway and the curb. A “quickie saw” shall not be used to perform curb removal.

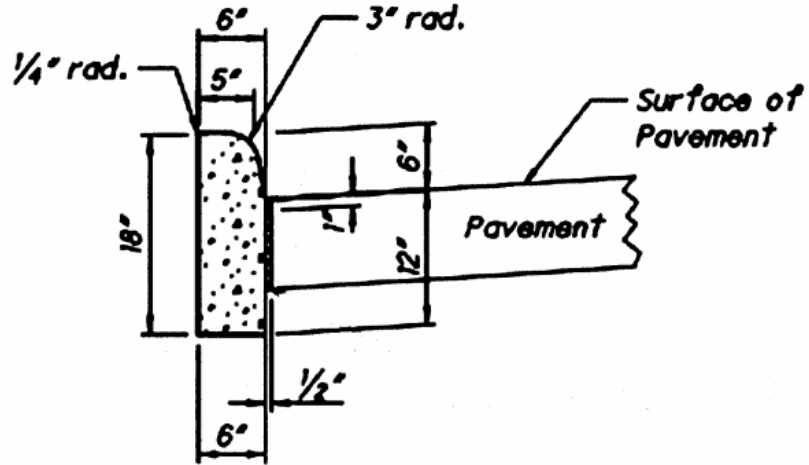

D. Debris removal from entire lot if needed

	<u>Address</u>	<u>Parcel Number</u>	<u>Replace Sidewalk</u>	<u>Replace Curb</u>	<u>Bid Price</u>
<u>Project 2024-Fall 24-08</u>	30 E. Raleigh Ave.	027-06-031-09-000	No	No	
	113 S. Foster St.	027-06-064-06-000	Yes (38')	No	
	118 S. Main St.	027-01-004-07-000	Yes (45')	No	
	205 Atcheson Ave.	027-03-131-14-000	No	No	
<u>Project 2024-Fall 24-09</u>	330 Newman St.	027-05-044-07-000	No	No	
	380½ Wayne St.	027-05-090-11-000	No	No	
	288 Central Ave.	027-05-054-13-000	Yes (50')	No	
	119 Snyder St.	027-05-046-11-000	Yes (38')	No	
<u>Project 2024-Fall 24-10</u>	353 Bowman St.	027-04-230-07-000	No	No	
	45 Orchard St.	027-04-025-08-000	Yes (20')	No	
	89 Orchard St.	027-04-232-04-000	Yes (70')	No	
	249 Clairmont Ave.	027-03-083-13-000	No	No	
Total Package Bid					

Dollars (\$ _____)

The Contractor shall complete the Work within **Thirty (30) days thereafter Notice being given that the demolition phase has completed and is therefore ready for Greening Phase per the scope of work**, unless Contractor has requested **IN WRITING AN EXTENSION** of the Contract beyond the Termination Date for good cause and the Contractor and City of Mansfield have consented in writing to such extension, which consent shall not be unreasonably withheld. Any extension of the Contract shall be made to a specified date (the "Extension Date"). It is agreed that time is of the essence under this Contract. There shall be deducted from the Contract Price, as an applicable credit to The City of Mansfield, Fifty and No/100 Dollars (\$50.00) for each calendar day that the completion of the Greening as specified in the contract extends beyond the Termination Date or the Extension Date, as applicable. **Completed Greening means all work listed in bid specifications.*
PAYMENT FOR CONTRACT WILL BE MADE AFTER ALL WORK LISTED IN BID SPECIFICATIONS HAS BEEN COMPLETED AND APPROVED.

The Contractor shall not be liable, however, for excusable delays, which include, but are not limited to:

- a. Acts of a government restricting labor, equipment or materials by reason of a declared emergency; or
- b. Causes beyond the control and without the fault or negligence of the Contractor, including, but not limited to, acts of God, fires, epidemics, quarantine restrictions, strikes, lockouts, freight embargoes, unavoidable delay in transportation, and unusual casualties; or
- c. Weather conditions of unusual severity, including but not limited to, the following:
 1. Winter Storm Warnings for Richland County issued by National Weather Service
 2. Wind Chill Warning for Richland County issued by National Weather Service
 3. Flood warnings for area where property is located issued by National Weather Service
 4. High Wind Warning for Richland County issued by National Weather Service
 5. Tornado Warning for Richland County issued by National Weather Service
 6. Excessive Heat Warning for Richland County issued by National Weather Service; or(Any extension of time requested for any of the above conditions must be accompanied with proof from National Weather Service).

Bids will be evaluated and awarded to the lowest and best bidder for the Project.

The above lump sum Project Bid Price for the listed Project shall include all labor, materials, bailing, shoring, removal, overhead, profit, insurance, etc., to cover the finished work of the several kinds called for with respect to the Project.

Bidder understands that the City of Mansfield reserves the right to reject any or all bids and to waive any informality in the bidding.

The bidder agrees that the bid for each Project shall remain in full force and effect (1) until the undersigned, if you are the successful bidder, has executed the Contract for such Project and the Work is completed or, (2) until the bid of another bidder has been awarded and he/she/it has executed a Contract for such Project.

Upon receipt of written NOTICE of AWARD / NOTICE to PROCEED for the Project set forth in this bid, the bidder will subsequently execute a formal Contract for the Project as attached hereto, with the required Performance Bond for the Project as well as the required Certificates of Insurance within ten (10) days.

By signing, contractor acknowledges the following: The bid will be awarded to the Lowest and Best bidder. Best" includes, but is not limited to: Contractor's financial position, including property, city, state and/or federal tax status, judgment liens, known experience, prior dealings with City and/or Land Bank, available equipment, ability

to execute work in accordance with all applicable guidelines and relevant laws, and performance on previous contracts. Bid will be considered if bid complies with bid specifications in all material respects and contains no irregularities or deviations from the specifications which would affect the amount of the bid or otherwise give the bidder a competitive edge. We reserve the right to waive any informality or to reject any bid(s) or all bids.

By signing this bid, Contractor agrees to sign contract within 14 days from notice that contract is ready for signatures. City of Mansfield shall consider all of the contractor's rights arising out of the City of Mansfield acceptance of the BID as abandoned after a 14-day period if the contract is not signed by the contractor. The City of Mansfield MAY offer the contract to the next lowest bidder.

Respectfully submitted: By: _____

Signature: _____ Title: _____