



City of Mansfield

Jodie Perry, Mayor

Bureau of Building Inspections, Licenses and Permits

30 N. Diamond Street - Mansfield, OH 44902 – (419)755-9688 permitting@ci.mansfield.oh.us
www.ci.mansfield.oh.us

Residential Deck and Ramp Plan Requirements

The deck/ramp plan approval process is a separate process required in addition to any Mansfield City Planning Commission approval requirements. The following document provides a background, commentary, and requirements for building plan approval.

This checklist is used to detail building plan requirements and construction document details for residential deck plans and documents submitted for review. Fees must be paid at the time of application before plan and document review commences. Please submit two (2) sets of plans and documents. Plans shall be neatly drawn to a consistent and recognized scale (1/4"=1' minimum). Plans are required to contain adequate information to be properly reviewed. Referring to code sections in general does not allow us to review proposed methods of construction. Plans containing general code references will be returned for more specific information. Drawings shall be reviewed under the most current edition of the Residential Code of Ohio (RCO).

General Plan and Application Information:

1. ___ Completed application for plan approval
2. ___ Items to be noted on the first sheet:
 - a. ___ Index of Drawings and number of pages
 - b. ___ Area in gross square feet

Site Plan: (minimum reqs. per RCO 106.1.3, No.2.)

3. ___ Shall be drawn to a recognized scale.
4. ___ Size and location of all existing and proposed structures.
5. ___ All property and interior lot lines with distances from lot lines.
6. ___ Setback and side yard dimensions.
7. ___ Locations of nearest streets.
8. ___ Types and sizes of all utility lines.
9. ___ Elevations of all proposed finished grades.
10. ___ Floodplain location

Deck Plans:

11. ___ Foundation Plan (R403)
 - a. ___ Post Hole Layout
 - b. ___ Post Hole Spacing
 - c. ___ Post Sizes
 - d. ___ Footing Diameter and thickness
12. ___ Floor Framing/Construction Plan (R502)
 - a. ___ Joist Size, Directions, and Spacing
 - b. ___ Decking Layout
 - c. ___ Locations of Doors and Stairs
 - d. ___ Handrail and Guardrail Locations
 - e. ___ Fixture and Receptacle Locations
 - f. ___ Locations of exterior doors adjacent to the deck.

Structural Design Information:

13. ___ Soil Bearing Pressure
14. ___ Floor Live Loads
15. ___ Lumber Sizes, Grades, and Species.

Elevation View of Exterior:

16. ___ Elevation Views of all sides of deck showing:
 - a. ___ Grade
 - b. ___ Deck
 - c. ___ House or other structure

Cross Sections shall contain:

17. ___ Footing size and depth
18. ___ Post Size and Spacing
19. ___ Exterior Grade
20. ___ Beam/Girder Details
21. ___ Ledger Board size and connection
22. ___ Connection/Fastener Details for
 - a. ___ Posts to Beam / Girder
 - b. ___ Ledger Board
 - c. ___ Floor Joists
 - d. ___ Guards/Railings and Posts
 - e. ___ Stair Stringers / Treads / Risers
23. ___ Floor Joist Size and Direction
24. ___ Decking
25. ___ Hand Rail Dimensions
26. ___ Guard Rail Dimensions
27. ___ Stair Tread and Riser Dimensions

Special Notes

- All Deck foundations shall comply with R403.4.
 - The minimum depth shall be 36" to the bottom of the footing for deck supported by a dwelling.
 - Per R403.1.4.1 Ex. No.3, Decks not supported by a dwelling need not be provided with footings that extend below the frost line. The minimum depth shall be 12 inches below grade.
- All lumber shall be pressure treated or decay resistant in locations defined by RCO 317.1.
- Fasteners for pressure preservative and fire-retardant-treated wood shall be of hot-dipped galvanized steel, stainless steel, silicon bronze or copper per RCO 317.3
- Refer to Section R311.8 for Ramp Requirements. Maximum slope of 1:8(12.5 percent, 1 unit vertical in 8 units horizontal), 36 inch landing at the top and bottom, door openings, and changes in direction. Handrails required on one side minimum.
- Ramps constructed to provide handicapped accessibility shall comply with ICC/ANSI A117.1 in accordance with RCO 320.1.

SECTION 311.7 STAIRWAYS (ABBREVIATED)

311.7.1 Width. Stairways shall not be less than 36 inches (914 mm) in clear width at all points above the permitted handrail height and below the required headroom height. Handrails shall not project more than 4.5 inches (114 mm) on either side of the stairway and the minimum clear width of the stairway at and below the handrail height, including treads and landings, shall not be less than 31½ inches (787 mm) where a handrail is installed on one side and 27 inches (698 mm) where handrails are provided on both sides.

Exception: The width of spiral stairways shall be in accordance with Section 311.7.9.1.

311.7.2 Headroom. The minimum headroom in all parts of the stairway shall not be less than 6 feet 8 inches (2032 mm) measured vertically from the sloped line adjoining the tread nosing or from the floor surface of the landing or platform on that portion of the stairway.

Exception: Where the nosings of treads at the side of a flight extend under the edge of a floor opening through which the stair passes, the floor opening shall be allowed to project horizontally into the required headroom a maximum of 4¾ inches (121 mm).

311.7.4 Stair treads and risers. Stair treads and risers shall meet the requirements of this section. For the purposes of this section all dimensions and dimensioned surfaces shall be exclusive of carpets, rugs or runners.

311.7.4.1 Riser height. The maximum riser height shall be 8 ¼ inches (196 mm). The riser shall be measured vertically between leading edges of the adjacent treads. The greatest riser height within any flight of stairs shall not exceed the smallest by more than 3/8 inch (9.5 mm).

311.7.4.2 Tread depth. The minimum tread depth shall be 9 inches (254 mm). The tread depth shall be measured horizontally between the vertical planes of the foremost projection of adjacent treads and at a right angle to the tread's leading edge. The greatest tread depth within any flight of stairs shall not exceed the smallest by more than 3/8 inch (9.5 mm). Consistently shaped winders at the walkline shall be allowed within the same flight of stairs as rectangular treads and do not have to be within 3/8 inch (9.5 mm) of the rectangular tread depth.

STAIR GEOMETRY

Stairs shall be constructed with the dimensions listed below.

- The minimum width of a stairway is 36 inches.
- Stair geometry and opening limitations shall meet the requirements shown in FIGURE 38. Treads, risers and nosing dimensions shall not deviate at each step by more than 3/8 inches.

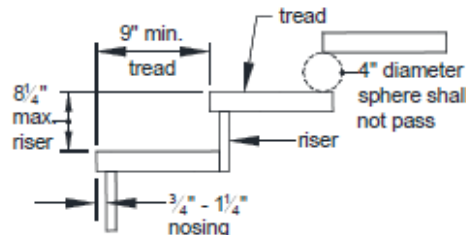

FIGURE 37: TREADS AND RISERS

STAIR LANDING

- If the total vertical height of a stairway exceeds 12 feet, then an intermediate landing is required and must be constructed as a free-standing deck.
- Stair landings may be constructed with 4x4 posts with post heights no greater than 8 feet.
- Landing widths shall be equal to the total width(s) of the stairway(s) served.

STAIR CONSTRUCTION

Stair stringers:

- Stringers shall be sawn or solid 2x12s complying with the tread and riser geometry requirements.
- Stringers shall be spaced at a maximum of 18 inches on center.
- Stringers shall bear on footings and attach to the deck or landing per FIGURE 39.
- Stringer span length is measured using the horizontally projected distance between the bearing at each end and shall not exceed the dimensions shown in FIGURE 40.

SOLID STRINGER EXCEPTION: Solid stringers of stairways with a width equal to 36 inches shall be permitted to have a span as shown in FIGURE 40.

- Throat size of cut stringers shall not exceed the value shown in FIGURE 40.

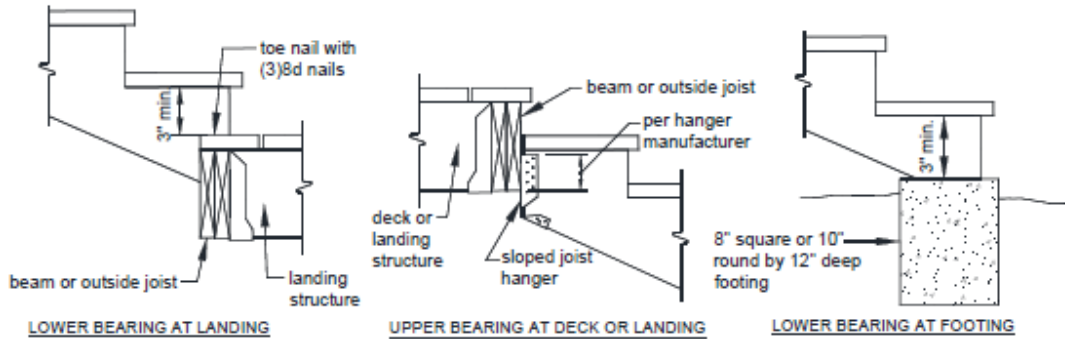

FIGURE 38: STRINGER BEARING

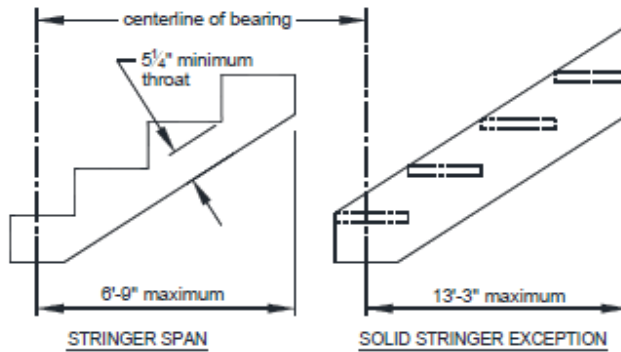

FIGURE 39: MAXIMUM STRINGER SPAN LENGTH

Tread and riser material:

- Tread material shall be equivalent to the decking specified on Page 4 and attached in accordance with FIGURE 41. The span of plastic composites shall be per manufacturer and in some cases may be less than 18 inches specified in FIGURE 41.
- Stairs constructed using the solid stringer exception shall have treads constructed of 2x wood material only, see FIGURE 41.
- Risers may be framed with 1x lumber minimum or equivalent plastic composite. Open risers are permitted provided the opening does not allow the passage of a 4-inch diameter sphere.

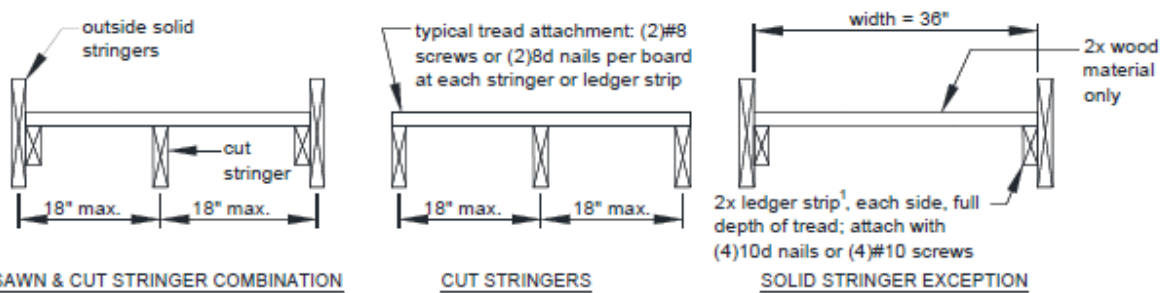

FIGURE 40: STRINGER TREADS

Stair guards. Stair guards are required when the total rise of the stair is greater than 30 inches at a point 36 inches from the edge of the stair. Stair guards shall be constructed in accordance with Section 8 and FIGURE 42.

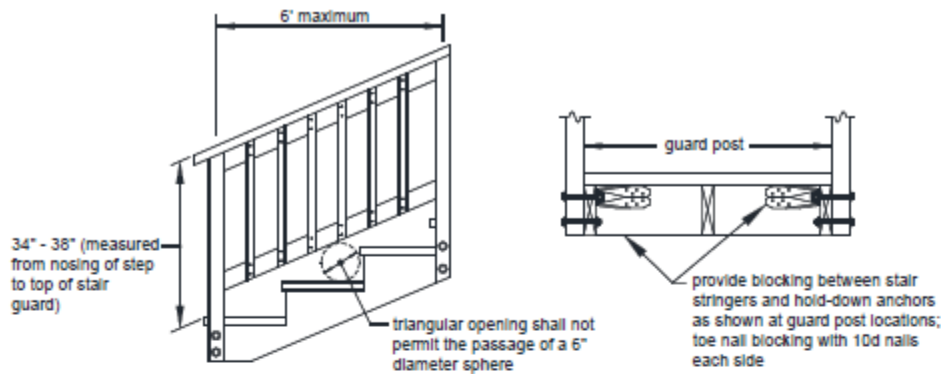

FIGURE 41: STAIR GUARD

Handrails:

- Stairs with four or more risers shall have a handrail on one side at a height between 34 to 38 inches above the nosing of the step.
- Handrails shall be attached to a stair guard or exterior wall acting as a barrier as shown in see FIGURE 43.
- Handrail and connecting hardware material shall be decay and corrosion resistant.
- Handrails shall have a smooth surface with no sharp corners and shall be graspable. Recessed sections may be shaped from a 2x6 or five-quarter board as shown in FIGURE 44.
- Handrails shall run continuously from a point directly over the lowest riser to a point directly over the highest riser and shall return to the guard or wall at each end.
- Handrails may be interrupted by guard posts at a turn in the stair only.
- Handrails installed in lieu of window safety glazing, as required on Page 5, shall be supported at appropriate intervals to ensure that when a 50-pound load is applied, the rail does not deflect into the glass.

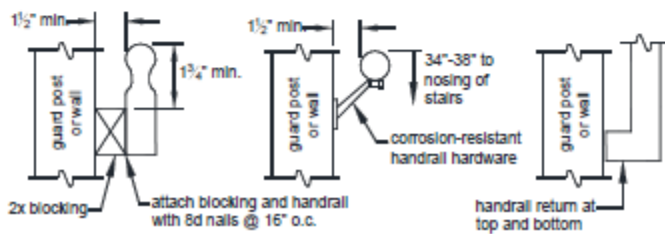

FIGURE 42: HANDRAILS

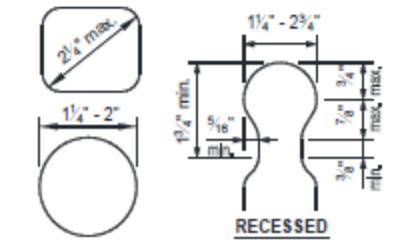

FIGURE 43: HANDRAIL GRASPABILITY

SECTION 312 GUARDS

312.1 Where required. Guards shall be located along open-sided walking surfaces, including stairs, ramps and landings, that are located more than 30 inches (762 mm) measured vertically to the floor or grade below at any point within 36 inches (914 mm) horizontally to the edge of the open side. Insect screening shall not be considered as a guard.

Exception: Guards are not required where a protective bar is installed 34 inches to 38 inches (864 mm to 965 mm) above the porch or deck on the interior side of the screening. The protective bar shall be capable of resisting a horizontal load of 50 pounds per lineal foot (730 N/m) without contacting the screen and be a minimum of 1 1/2 inches (38 mm) in height.

312.2 Height. Required guards at open-sided walking surfaces, including stairs, porches, balconies or landings, shall be not less than 36 inches (914 mm) high measured vertically above the adjacent walking surface, adjacent fixed seating or the line connecting the leading edges of the treads.

Exceptions: 1. Guards on the open sides of stairs shall have a height not less than 34 inches (864 mm) measured vertically from a line connecting the leading edges of the treads.

2. Where the top of the guard also serves as a handrail on the open sides of stairs, the top of the guard shall not be not less than 34 inches (864 mm) and not more than 38 inches (965 mm) measured vertically from a line connecting the leading edges of the treads.

312.3 Opening limitations. Required guards shall not have openings from the walking surface to the required guard height which allow passage of a sphere 4 inches (102 mm) in diameter.

Exceptions: 1. The triangular openings at the open side of a stair, formed by the riser, tread and bottom rail of a guard, shall not allow passage of a sphere 6 inches (153 mm) in diameter.

2. Guards on the open sides of stairs shall not have openings which allow passage of a sphere 43/8 inches (111 mm) in diameter.

312.4 Exterior woodplastic composite guards. Woodplastic composite guards shall comply with the provisions of Section 317.4.

GUARD CONSTRUCTION

A guard is required when a deck is greater than 30 inches above grade at a point 36 inches from the edge of the deck, as shown in FIGURE 33. Guards shall be constructed in accordance with the requirements herein; deviations are prohibited. Guards which are not required, but are nevertheless provided, must also comply with these requirements.

Plastic composites. Plastic composites of equal dimension and complying with the criteria noted on Page 3 may be substituted for the guard cap and infill elements shown in FIGURE 34 provided the manufacturer's performance criteria specifically permit such use.

Guard systems. Guard systems with a valid evaluation report from an accredited listing agency are permitted as referenced on Page 3. Pre-fabricated systems without an evaluation report will require a plan review during the permit application process.

Openings. Guards shall be constructed to restrict the passage of a 4-inch diameter sphere through any opening. Wet lumber shall be spaced such that when shrinkage occurs, a compliant opening is maintained.

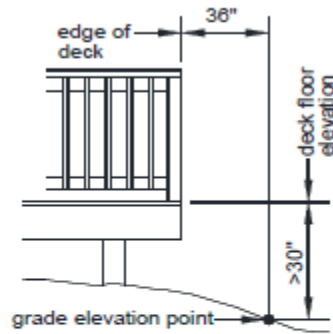

FIGURE 32: WHEN A GUARD IS REQUIRED

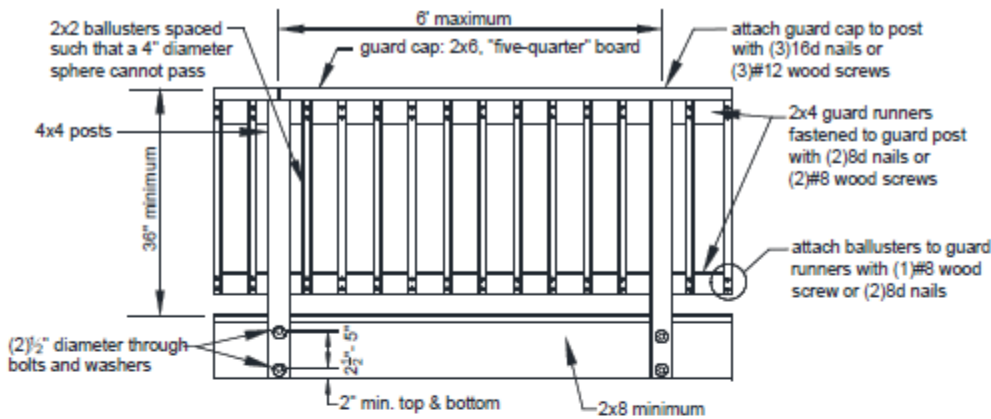

FIGURE 33: GUARD CONSTRUCTION

GUARD POST CONNECTION

Guard posts shall be attached to the deck structure in accordance with the requirements below in order to ensure resistance to imposed loads.

- Notching guard posts, as shown in FIGURE 35, is prohibited.
- Hold-down anchors, as shown in FIGURES 37 and 38, shall be used to attach the guard post to the end joist and rim joist, respectively.
- Hold-down anchors shall have a minimum capacity of 1,800 pounds.
- Guards may be attached to either side of the rim joist or end joist.



FIGURE 34: POST NOTCHES PROHIBITED

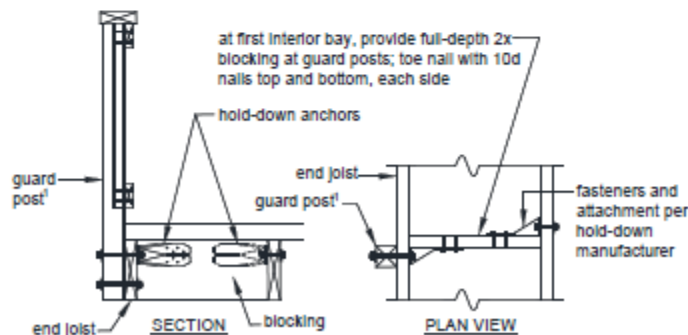

FIGURE 35: GUARD POST-TO-END JOIST

R403.5 Exterior deck footings.

Exterior deck footings of poured-in-place concrete shall be a minimum of 8 inches (203 mm) thick and extend below the frost depth per Table R301.2 (1). The diameter or width of the footing shall comply with Table R403.5.

TABLE R403.5 MINIMUM FOOTING SIZE FOR DECK FOOTINGS WITHOUT ROOF LOADS

EXTERIOR DECK AND PORCH FOOTING SIZE IN INCHES <i>a, b</i>			Footnotes
Diameter	Square	Maximum tributary area allowed per post (square feet)	<p>a. Based upon 2,000 pounds per square foot soil bearing capacity.</p> <p>b. Based upon 40 pounds per square foot live load and 10 pounds per square foot dead load.</p>
8	8x8	14	
10	9x9	22	
12	11x11	31.6	
14	13x13	42.8	
16	15x15	56	
18	16x16	70.8	
20	18x18	87.2	

502.2.2 Decks. Where supported by attachment to an exterior wall, decks shall be positively anchored to the primary structure and designed for both vertical and lateral loads as applicable. Such attachment shall not be accomplished by the use of toenails or nails subject to withdrawal. Where positive connection to the primary building structure cannot be verified during inspection, decks shall be self-supporting. For decks with cantilevered framing members, connections to exterior walls or other framing members, shall be designed and constructed to resist uplift resulting from the full live load specified in Table 301.5 acting on the cantilevered portion of the deck.

502.2.2.1 Deck ledger connection to band joist. For decks supporting a total design load of 50 pounds per square foot (2394 Pa) [40 pounds per square foot (1915 Pa) live load plus 10 pounds per square foot (479 Pa) 4101:8-5-01 3 dead load], the connection between a deck ledger of pressure-preservative treated Southern Pine, incised pressure-preservative-treated Hem-Fir or approved decay-resistant species, and a 2-inch (51 mm) nominal lumber band joist bearing on a sill plate or wall plate shall be constructed with ½-inch (12.7 mm) lag screws or bolts with washers in accordance with Table 502.2.2.1. Lag screws, bolts and washers shall be hot-dipped galvanized or stainless steel.

502.2.2.1.1 Placement of lag screws or bolts in deck ledgers. The lag screws or bolts shall be placed 2 inches (51 mm) in from the bottom or top of the deck ledgers and between 2 and 5 inches (51 and 127 mm) in from the ends. The lag screws or bolts shall be staggered from the top to the bottom along the horizontal run of the deck ledger.

502.2.2.2 Alternate deck ledger connections. Deck ledger connections not conforming to Table 502.2.2.1 shall be designed in accordance with accepted engineering practice. Girders supporting deck joists shall not be supported on deck ledgers or band joists. Deck ledgers shall not be supported on stone or masonry veneer.

502.2.2.4 Exterior wood/plastic composite deck boards. Wood/plastic composite deck boards shall be installed in accordance with the manufacturer's instructions.

**TABLE 502.2.2.1
FASTENER SPACING FOR A SOUTHERN PINE OR HEM-FIR DECK LEDGER
AND A 2-INCH NOMINAL SOLID-SAWN SPRUCE-PINE-FIR BAND JOIST *c, f, g*
(Deck live load = 40 psf, deck dead load = 10 psf)**

JOIST SPAN	6' and less	6' 1" to 8'	8' 1" to 10'	10' 1" to 12'	12' 1 "to 14'	14' 1" to 16'	16' 1" to 18'
Connection details	On-center spacing of fasteners <i>d, e</i>						
½ inch diameter lag screw with 15/32 inch maximum sheathing <i>a</i>	30	23	18/	15	13	11	10
½ inch diameter bolt with 15/32 inch maximum sheathing	36	36	34	29	24	21	19
½ inch diameter bolt with 15/32 inch maximum sheathing and ½ inch stacked washers <i>b, h</i>	36	36	29	24	21	18	16

For SI: 1 inch = 25.4 mm, 1 foot = 304.8 mm. 1 pound per square foot = 0.0479kPa.

- a. The tip of the lag screw shall fully extend beyond the inside face of the band joist.
- b. The maximum gap between the face of the ledger board and face of the wall sheathing shall be ½".
- c. Ledgers shall be flashed to prevent water from contacting the house band joist.
- d. Lag screws and bolts shall be staggered in accordance with Section 502.2.2.1.1.
- e. Deck ledger shall be minimum 2x8 pressure-preservative-treated No.2 grade lumber, or other approved materials as established by standard engineering practice.
- f. When solid-sawn pressure-preservative-treated deck ledgers are attached to a minimum 1 inch thick engineered wood product (structural composite lumber, laminated veneer lumber or wood structural panel band joist), the ledger attachment shall be designed in accordance with accepted engineering practice.
- g. A minimum 1 x9½ Douglas Fir laminated veneer lumber rimboard shall be permitted in lieu of the 2-inch nominal band joist.
- h. Wood structural panel sheathing, gypsum board sheathing or foam sheathing not exceeding 1 inch in thickness shall be permitted. The maximum distance between the face of the ledger board and the face of the band joist shall be 1 inch.

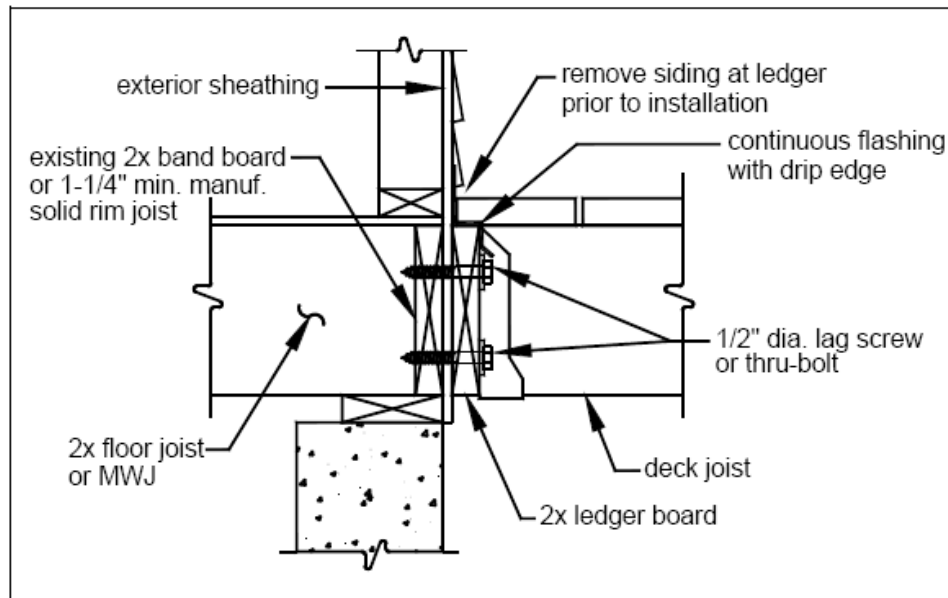

FIGURE 5: ATTACHMENT OF LEDGER BOARD-TO-BAND BOARD

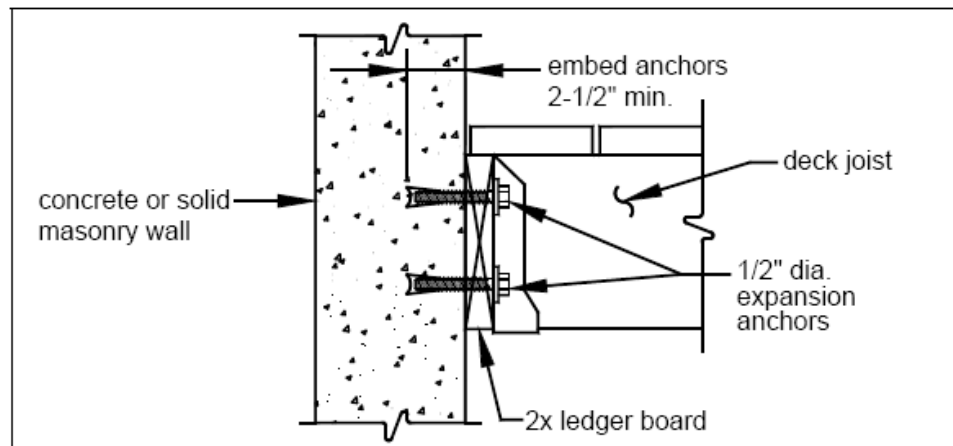

FIGURE 6: ATTACHMENT OF LEDGER BOARD-TO-FOUNDATION WALL (CONCRETE OR SOLID MASONRY)

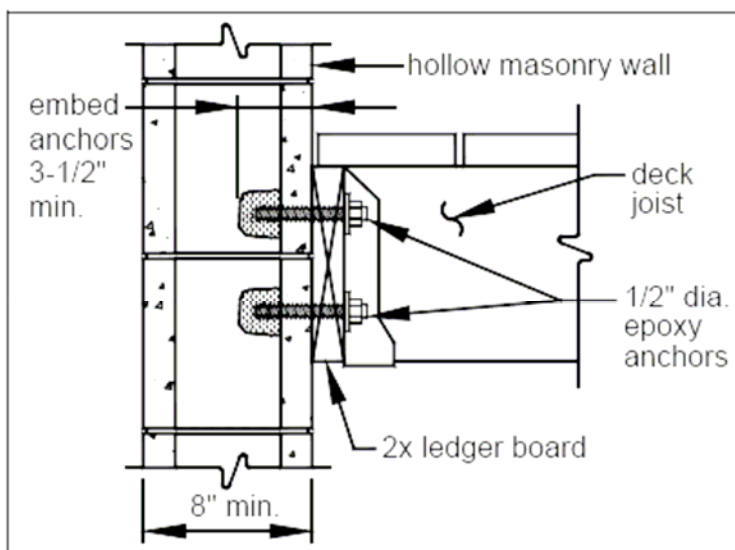
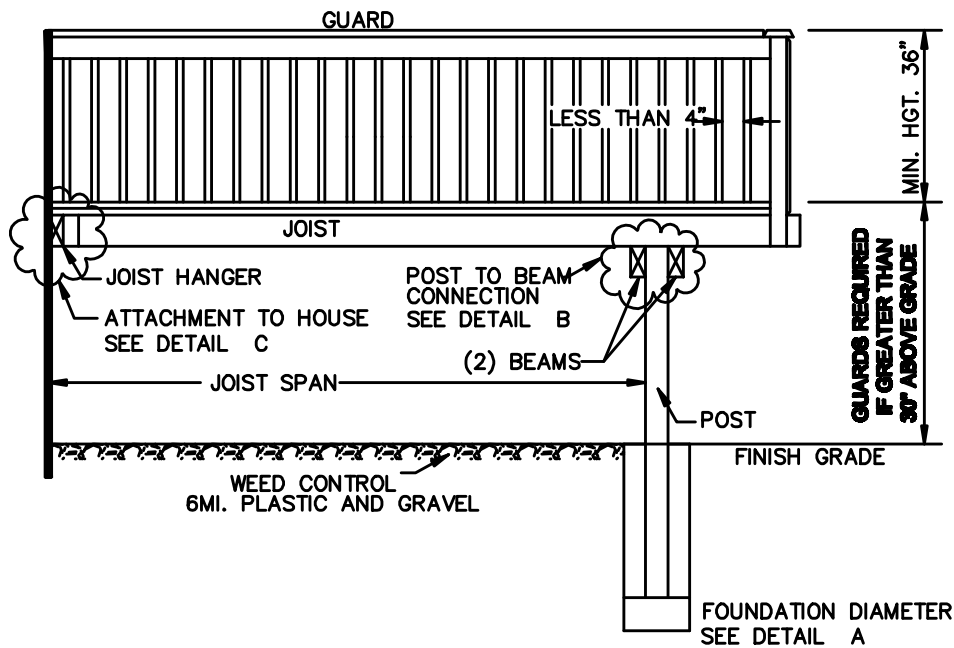

FIGURE 7: ATTACHMENT OF LEDGER BOARD-TO-FOUNDATION WALL (HOLLOW MASONRY)

SUBMIT THIS SHEET WITH APPLICATION

Residential Deck



CIRCLE EACH DETAIL THAT APPLIES

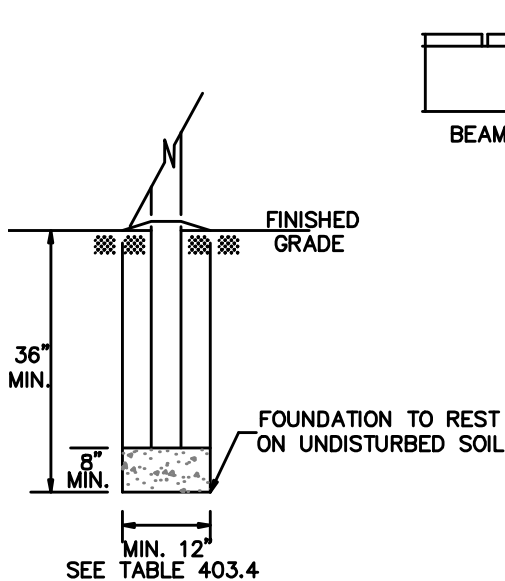

DETAIL A

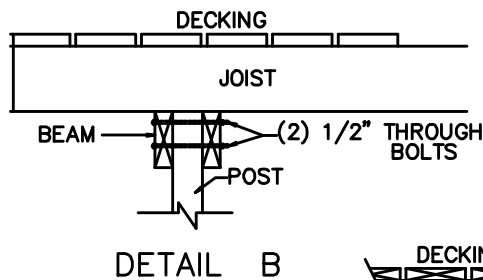

DETAIL B

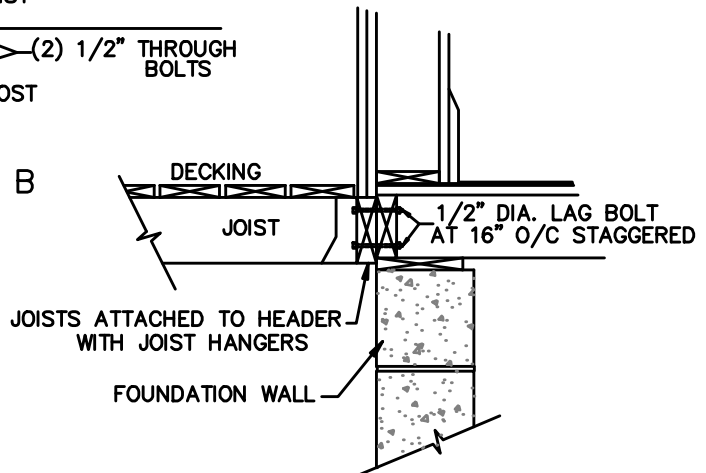

DETAIL C

SAMPLE

Residential Deck

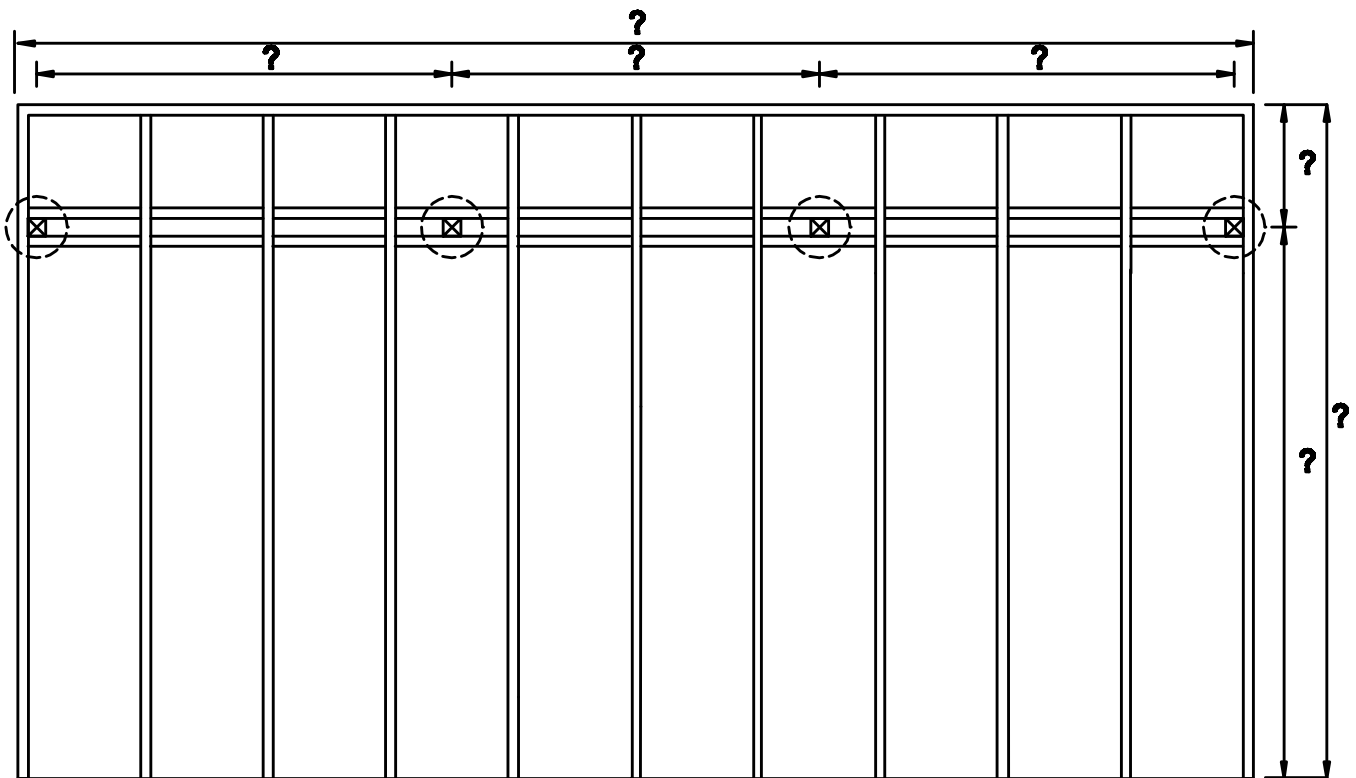

PROVIDE POST TO POST AND OVERALL DIMENSIONS

How To Calculate Deck Footings

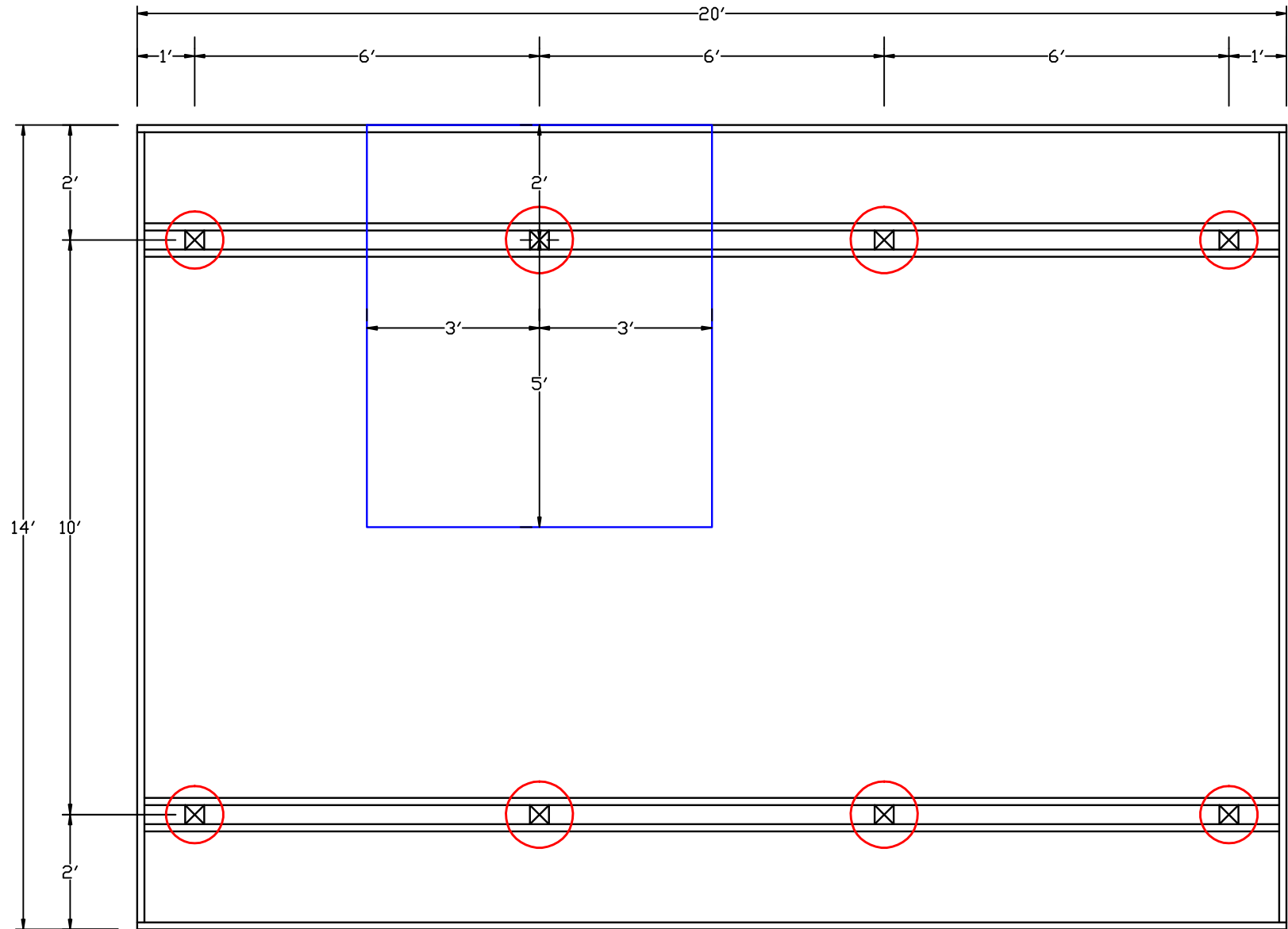

STAIR REQUIREMENTS

Stairs, stair stringers, and stair guard shall meet the requirements shown in FIGURE 27 through FIGURE 33. All stringers shall be 2x12.

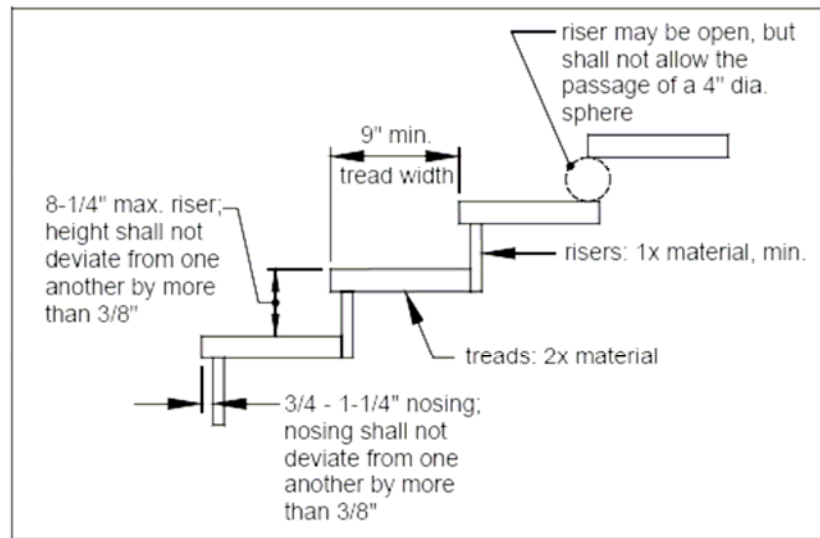

FIGURE 27: TREAD AND RISER DETAIL

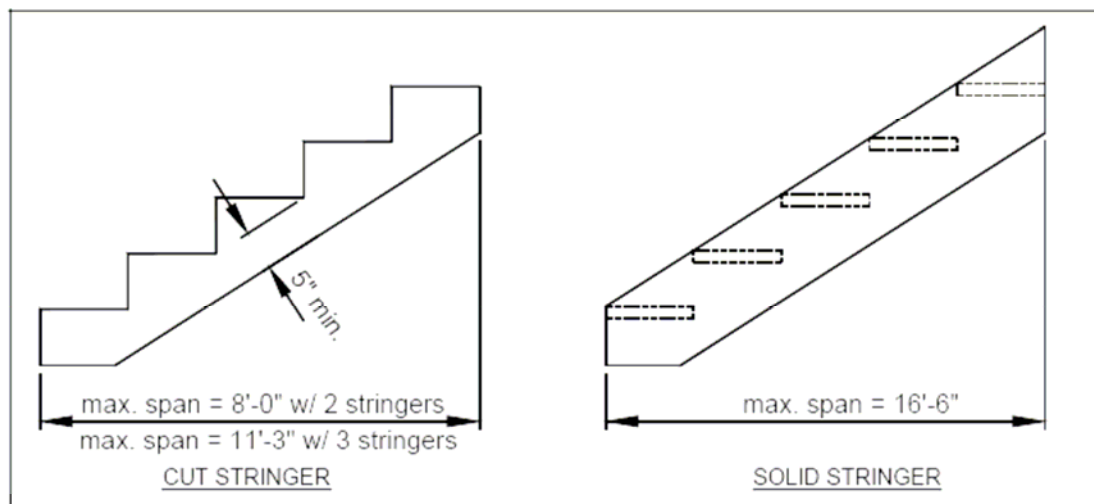

FIGURE 28: STAIR STRINGER REQUIREMENTS

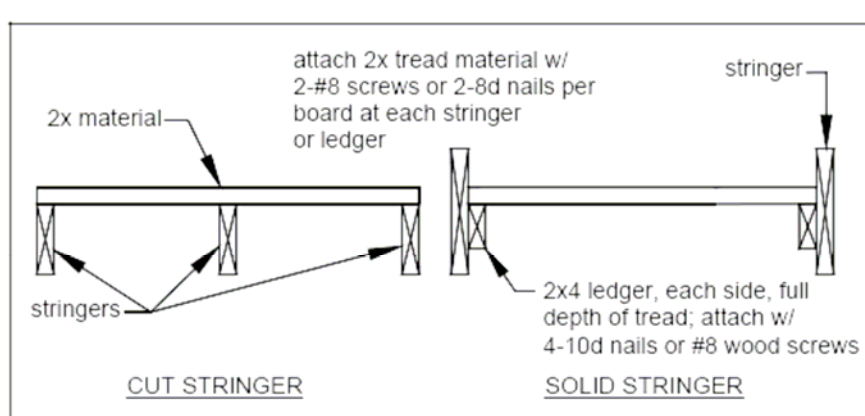

FIGURE 29: TREAD CONNECTION REQUIREMENTS

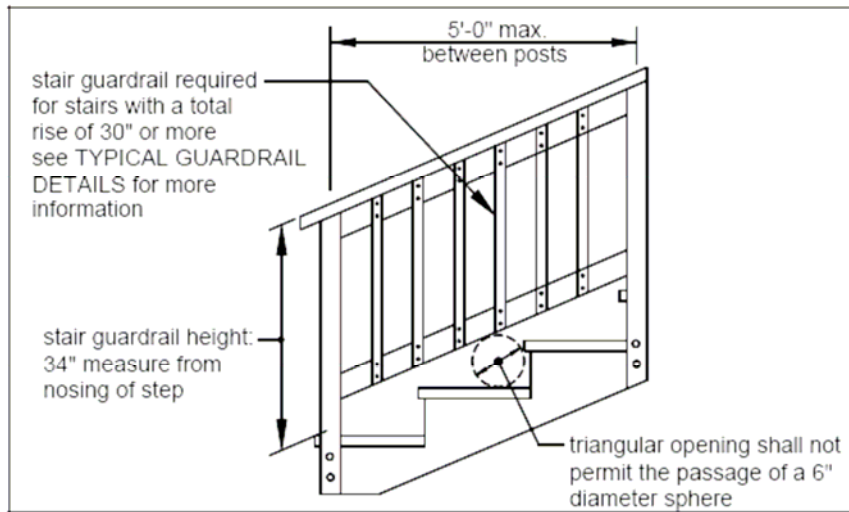

FIGURE 30: STAIR GUARD REQUIREMENTS

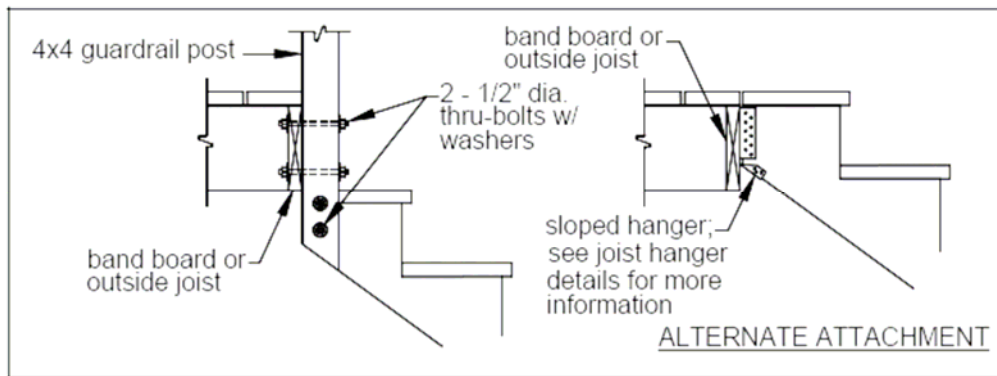

FIGURE 31: STAIR STRINGER CONNECTION DETAIL

STAIR HANDRAIL REQUIREMENTS

All stairs with 2 or more risers shall have a handrail on one side. Handrails shall be graspable and shall be composed of decay-resistant and/or corrosion resistant material. The hand grip portion, if circular, shall be between 1-1/4" and 2-1/4" in cross section. Shapes other than circular shall have a perimeter dimension between 4" and 6-1/4" with a maximum cross sectional dimension of 2-1/4". All shapes shall have a smooth surface with no sharp corners. Handrails shall run continuously from a point directly over the lowest riser to a point directly over the highest riser and shall return to the guard at each end; see FIGURE 33. Handrails may be interrupted at guards posts only at a turn in the stair. See FIGURE 32.

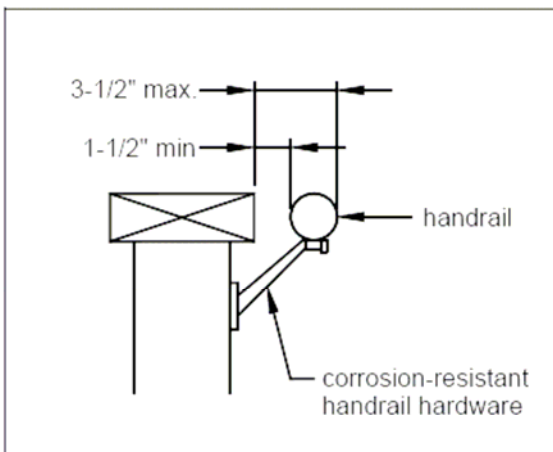

FIGURE 32: HANDRAIL REQUIREMENTS

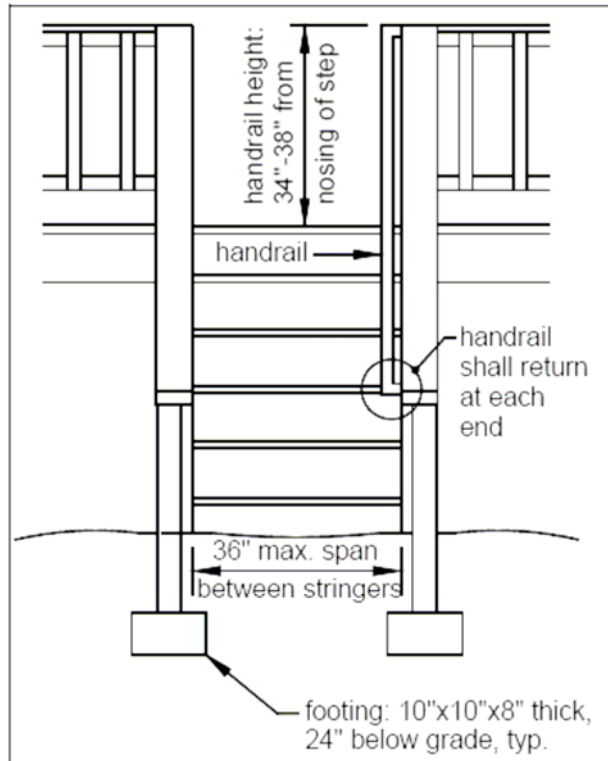

FIGURE 33: MISCELLANEOUS STAIR REQUIREMENTS

STAIR ILLUMINATION REQUIREMENTS

Stairways shall have a light source located at the top landing such that all stairs and landings are illuminated. The light switch shall be operated from inside the house.

FRAMING AT CHIMNEY OR BAY WINDOW

All members at a chimney or bay window shall be framed in accordance with FIGURE 34. Headers with a span length greater than 6'-0" require a plan submission.

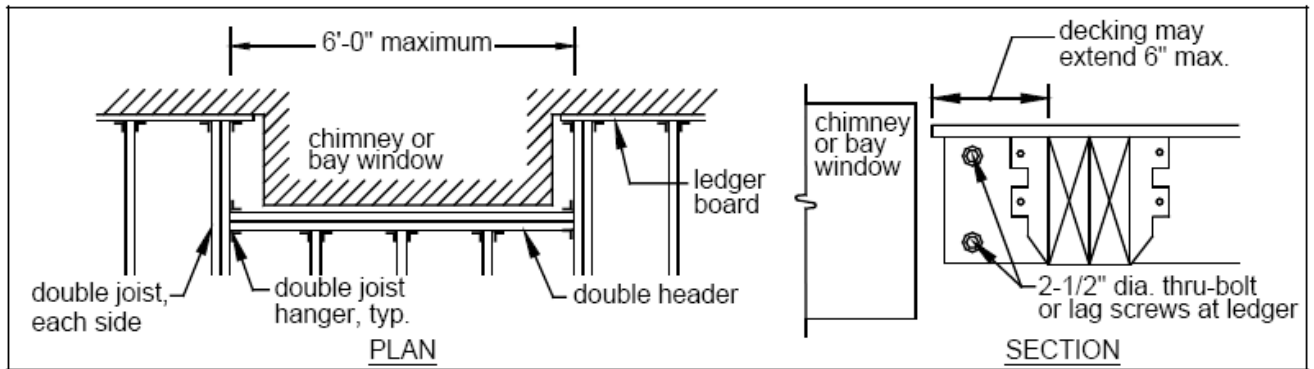

FIGURE 34: REQUIREMENTS FOR FRAMING AT CHIMNEY OR BAY WINDOW